

CONTROL TRANSFORMER PRIMARY CONNECTIONS			
INPUT VOLTS	TERMINALS		JUMPER LOCATION
	A	B	
208	(H1)	(H2)	NONE
460/480	(H1)	(H4)	(H2) TO (H3)

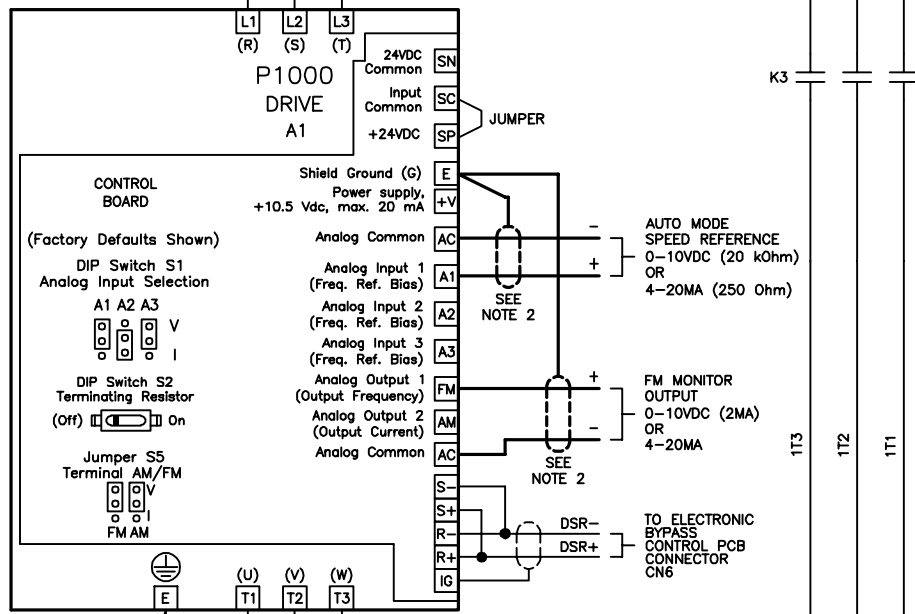

- NOTES:
1. CUSTOMER TO CONNECT THE CABINET GROUND LUG TO EARTH GROUND.
 2. INSULATED TWISTED SHIELDED WIRE IS REQUIRED. SHIELD TO CONNECT TO PROPER TERMINAL AS SHOWN. CONNECT THE SHIELD ONLY AT THIS END. STUB AND ISOLATE THE OTHER END. DO NOT RUN THESE WIRES IN THE SAME CONDUIT AS THE AC POWER AND THE AC CONTROL WIRES.
 3. WITH A CONTROL TRANSFORMER, T1, POWER RATING 350VA OR GREATER, SECONDARY FUSE F6 IS ADDED.
 4. CHANGING Z1-01 TO "1" WILL PROGRAM THE DRIVE AND BYPASS PARAMETERS TO THEIR FACTORY DEFAULT SETTINGS.
 5. FOR 208VAC APPLICATIONS, SET E1-01 TO 208 AND SET E1-05 TO 208.
 6. THE MOTOR OVERLOAD RELAYS ARE FACTORY SET FOR MANUAL RESET. CUSTOMER TO ADJUST THE MOTOR OVERLOAD RELAYS TRIP SETTINGS FOR THE ACTUAL AC MOTOR'S FULL LOAD AMPS.
 7. CONDUIT FITTINGS/HUBS SHALL COMPLY WITH THE 'STANDARD FOR CONDUIT, TUBING, AND CABLE FITTINGS, UL 514B'. OR CONDUIT FITTINGS HAVING THE SAME ENVIRONMENTAL RATING AS THE ENCLOSURE SHALL BE USED.

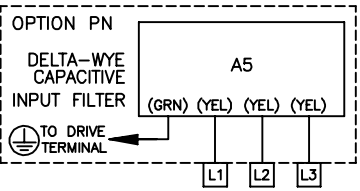
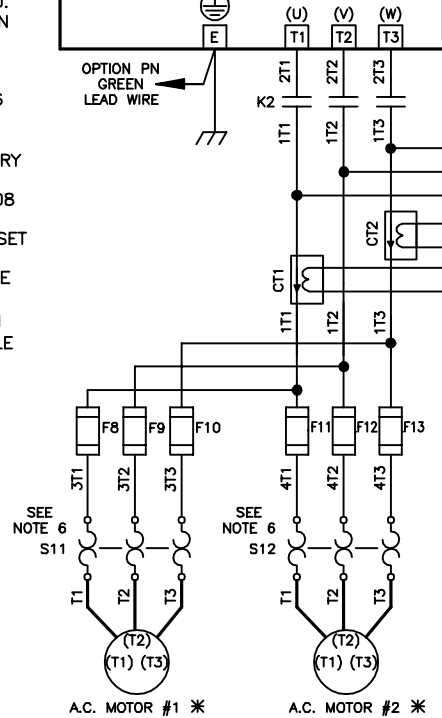
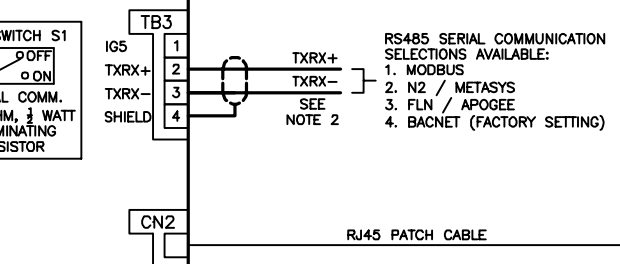
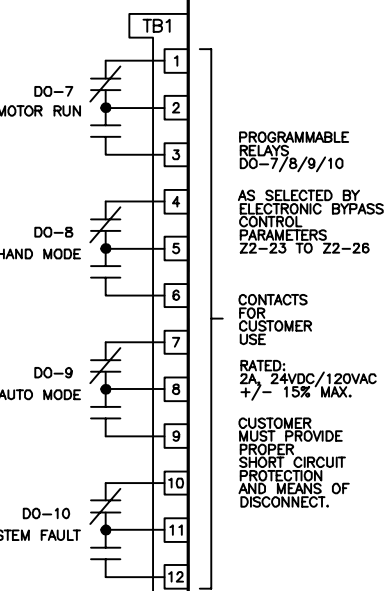
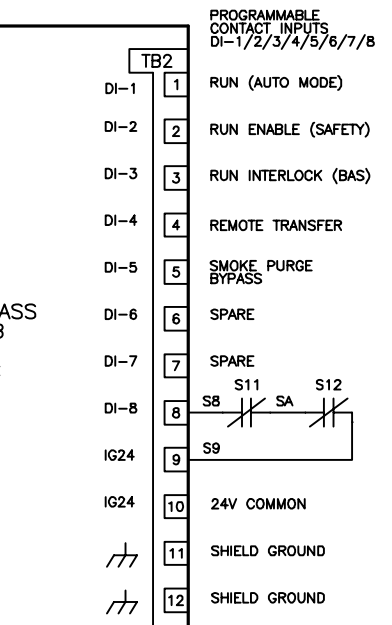
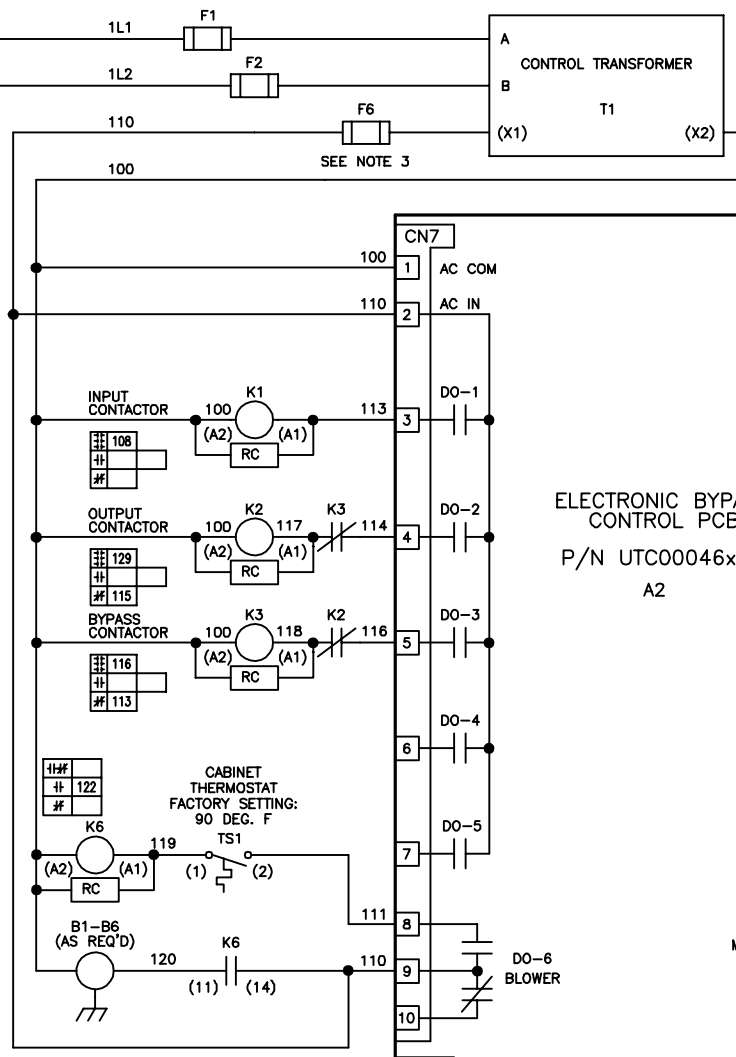

* - INDICATES COMPONENTS NOT SUPPLIED BY YASKAWA.
 --- - INDICATES CUSTOMER WIRING.
 ⏏ - CONNECTED TO THE CABINET OR PANEL.

REVISIONS				
REV.	DESCRIPTION	ECO #	DRAWN BY	DATE
01	REMOVE TG & TH OPTIONS FROM P1000 BYPASS	12946	JZ	3/13/23
00	INITIAL RELEASE	-	D. PACKER	11/30/13

YASKAWA

THIS DOCUMENT AND INFORMATION CONTAINED IN IT ARE CONFIDENTIAL, AND CANNOT BE COPIED OR DISCLOSED IN WHOLE OR IN PART WITHOUT THE EXPRESS WRITTEN CONSENT OF YASKAWA AMERICA INC.

DRAWN BY: D. CMELAK	DATE: 11/30/13	TITLE: SCHEMATIC DIAGRAM P1000 ELECTRONIC BYPASS 2-MTR "AND" OPTION PA
CHECKED: D. PACKER	DATE: 11/30/13	
APPROVED: K. FLIERL	DATE: 11/30/13	
ORIGINAL DESIGN: D. CMELAK	DATE: 11/30/13	

SIZE: D REVISION: 01 PAGE: 1 of 1

DRAWING #: DS.P1B.112.06